





DNM AMORTIGUADOR – TIPO NEUMÁTICO BURNER-RCP 2S

Descripción de símbolos /  : Advertencia  : Atención

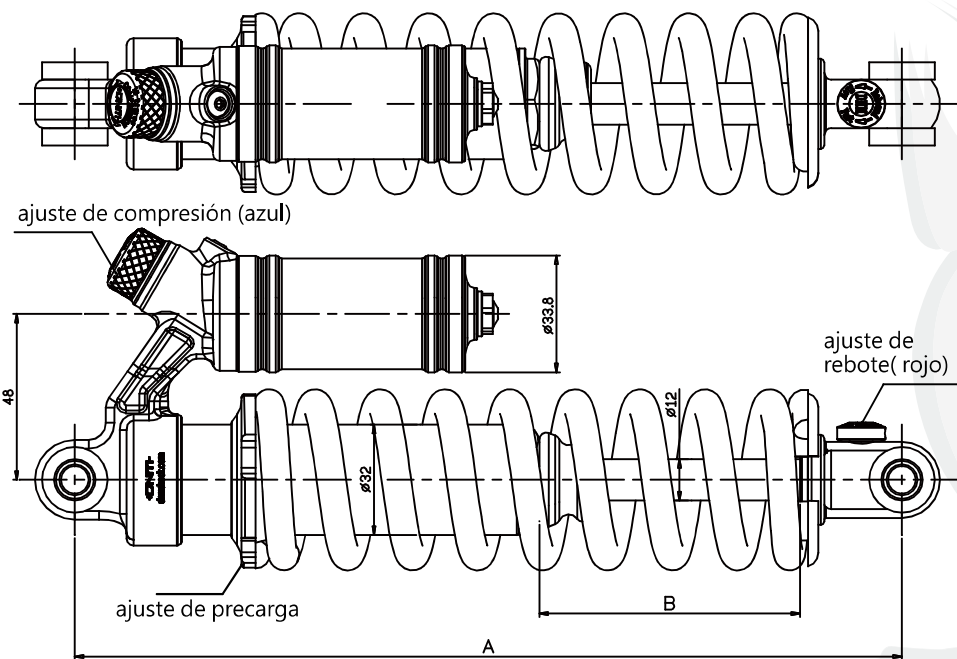

 **ajuste de compresión**
Gire hacia + , aumenta precisión
Gire hacia - , disminuye precisión

 **ajuste de rebote**
Gire hacia + , aumenta amortiguación(lento)-
Gire hacia - , disminuye amortiguación (rápido)

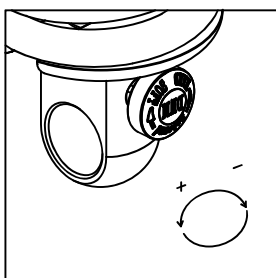
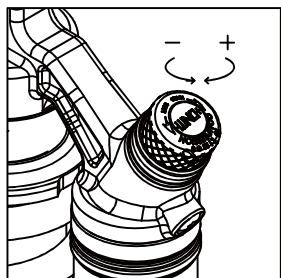

Especificación	
A longitud	B recorrido
190±2	51±2
200±2	56±2
210±2	61±2
220±2	66±2
240±2	76±2
265±2	85±2

DNM AMORTIGUADOR – TIPO MUELLE RCP2 -AR

Descripción de símbolos /  : Advertencia  : Atención

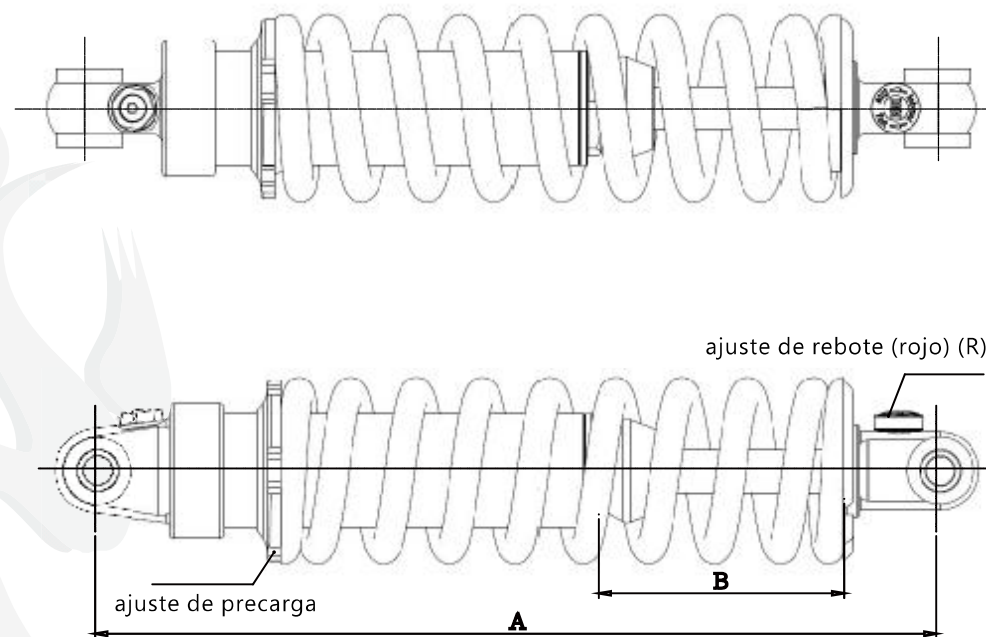

 **Ajuste de rebote**
Gire hacia + , aumenta amortiguación(lento)
Gire hacia - , disminuye amortiguación (rápido)

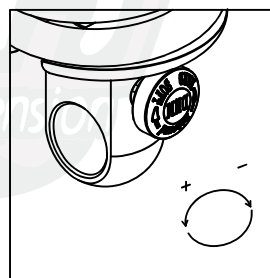

Especificación	
A longitud	B recorrido
210±2	53 ±2
220±2	58 ±2
240±2	68 ±2
265±2	73 ±2

DNM Spring Shocks BURNER-RCP2S Description

Diagram Consumer Safety /  : Warning  : Attention

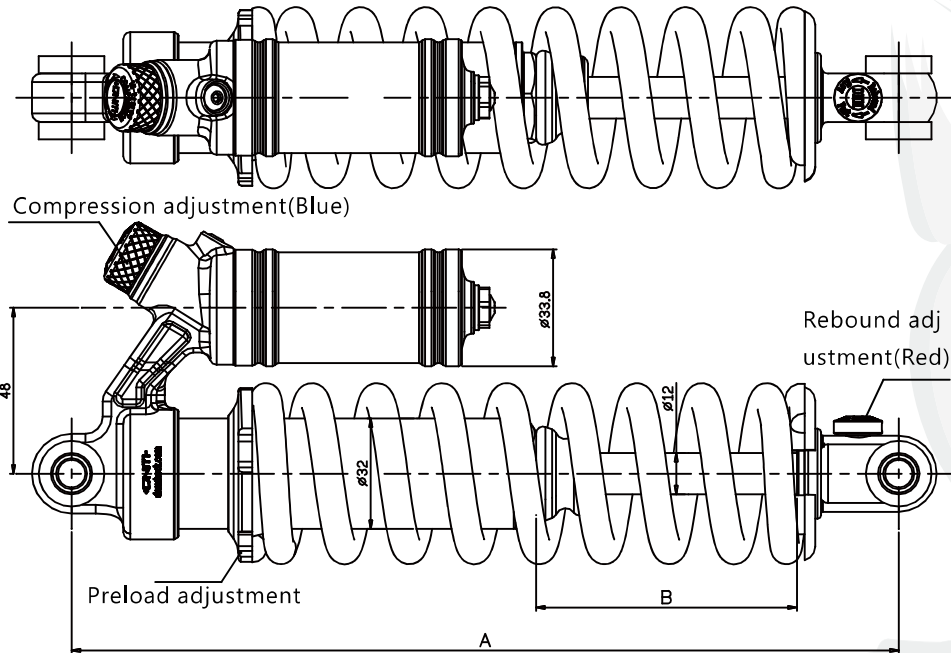

Compression adjustment

+ direction rotation, pressure increase
- direction rotation, pressure decrease

Rebound adjustment

+ direction rotation, damper increase (slow)
- direction rotation, damper decrease (fast)

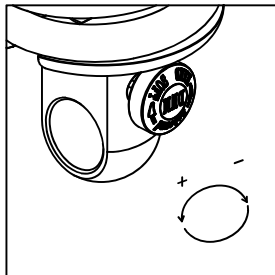
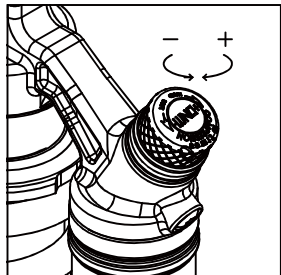

specification	
A Total Length	B Route
190±2	51±2
200±2	56±2
210±2	61±2
220±2	66±2
240±2	76±2
265±2	85±2

DNM Spring Shocks RCP2-AR Description

Diagram Consumer Safety /  : Warning  : Attention

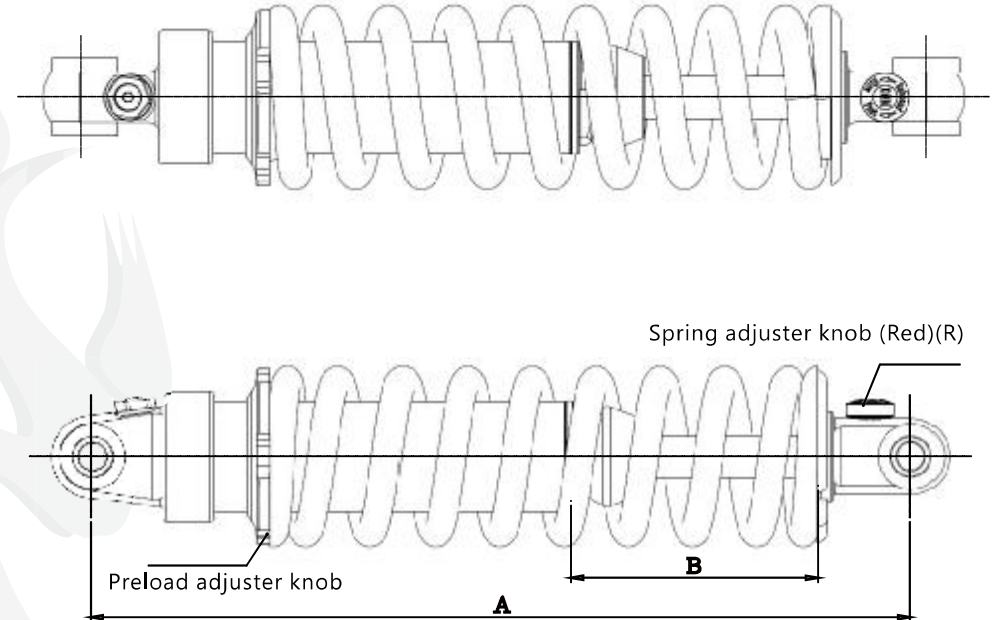

Rebound adjustment

+ direction rotation, damper increase (slow)
- direction rotation, damper decrease (fast)

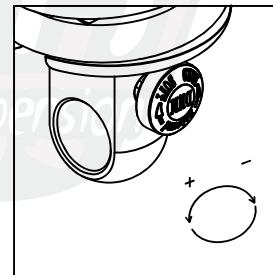

specification	
A Total Length	B Route
210±2	53 ± 2
220±2	58 ± 2
240±2	68 ± 2
265±2	73 ± 2

DNM 避震-彈簧式 BURNER-RCP 2S 說明解說

圖示說明 /



: 警告



: 注意

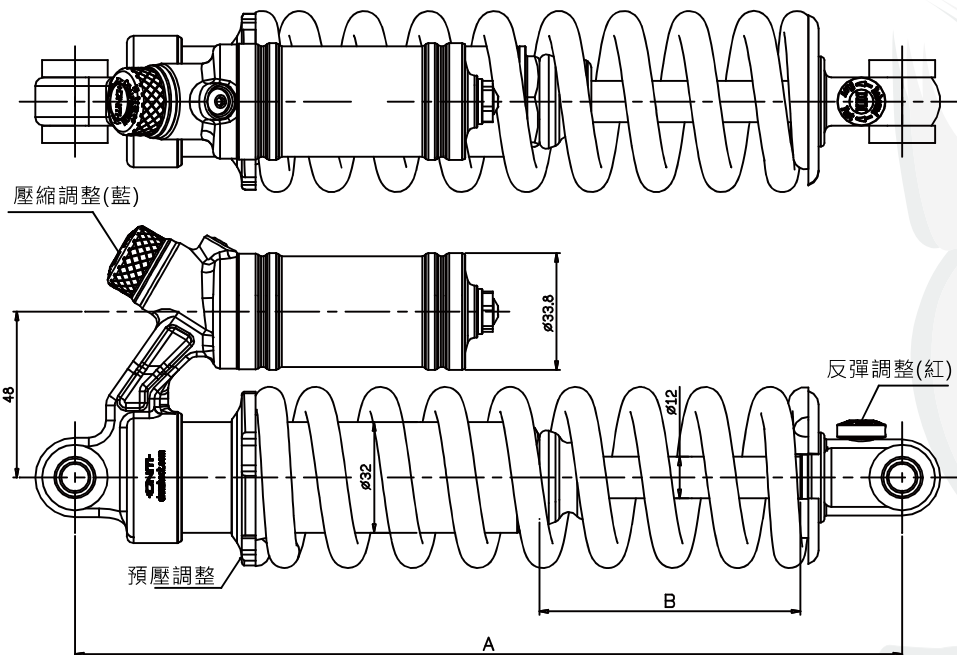

! 壓縮調整

- +方向旋轉 · 壓力增加
- 方向旋轉 · 壓力減少

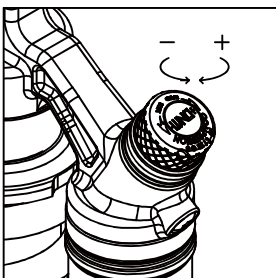

! 反彈調整

- +方向旋轉 · 阻尼增加(慢)
- 方向旋轉 · 阻尼減少(快)

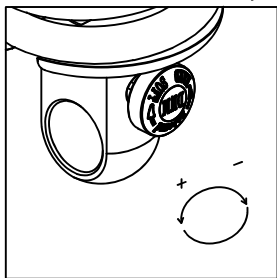

規 格	
A總長	B行程
190±2	51±2
200±2	56±2
210±2	61±2
220±2	66±2
240±2	76±2

DNM 避震-彈簧式 RCP2-AR 說明解說

圖示說明 /



: 警告

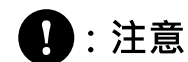

: 注意

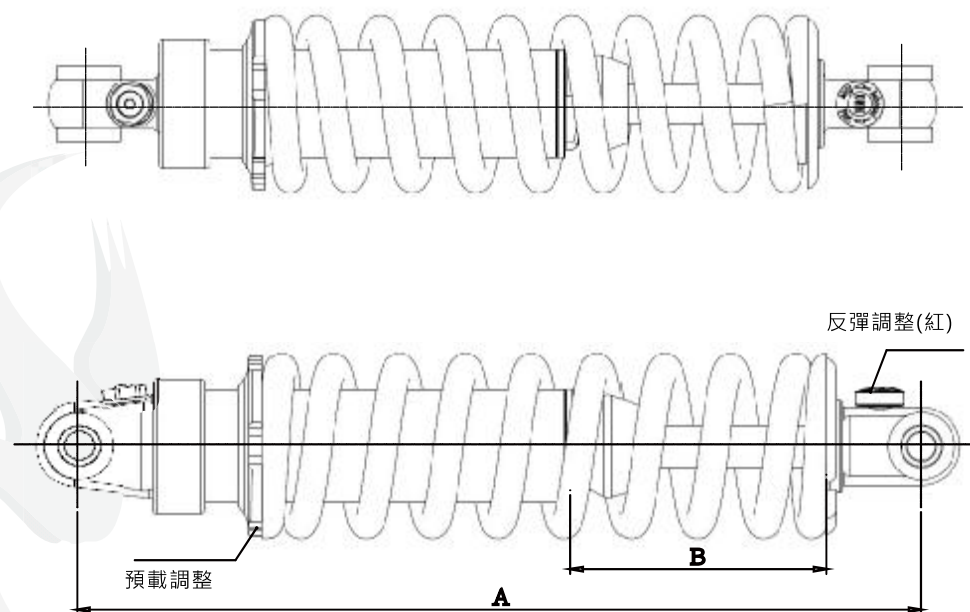

! 反彈調整鈕

- +方向旋轉 · 阻尼增加(慢)
- 方向旋轉 · 阻尼減少(快)

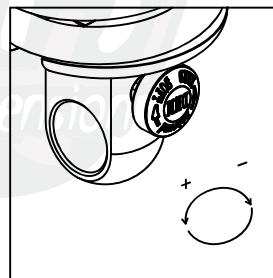

規 格	
A總長	B行程
210±2	53 ±2
220±2	58 ±2
240±2	68 ±2
265±2	73 ±2